

JT-4508

攻牙機
TAPPING MACHINE

攻牙行程
TAPPING STROKE

最大攻牙
MAX TAPPING

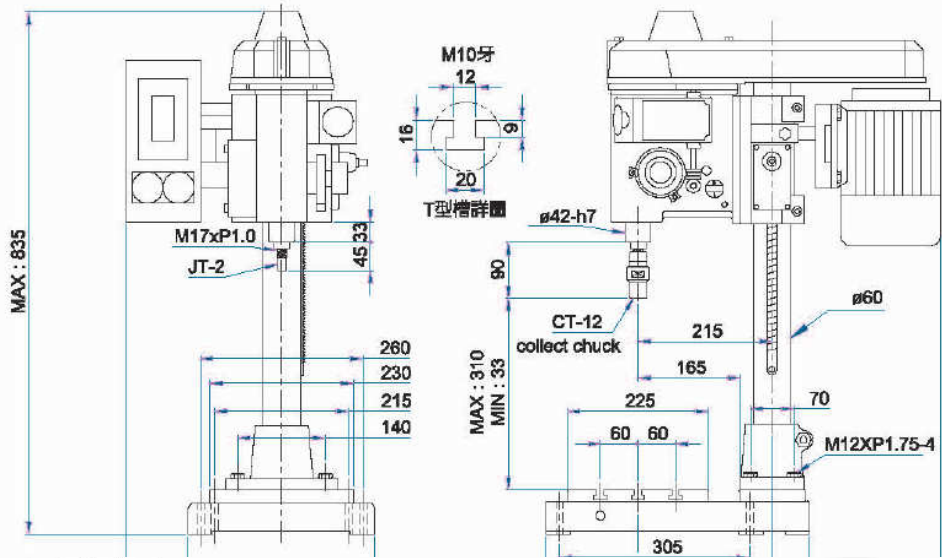

規格表 / Specification

機種 Model	規格 Specification	主軸最大行程 Main spindle max. stroke (mm)	主軸前部型式 Type of the front side of Main spindle (mm)	螺牙直徑 Diameter of thread (mm)	多軸最大能力 Max. capacity of Multi-spindle	主軸端和台之距離 Distance between the main spindle and the table (mm)	工作台尺寸 Working table size (mm)	馬達 Motor	主軸迴轉數 Main spindle speed (R.P.M)		符合本機器使用之自動送料螺距 Auto feeding thread pitch for which suits machine		裝箱尺寸 Packing dimension (cm)	毛重 G. Weight (kg)
									50HZ	60HZ	每英寸的牙數 Range of TPI	mm		
直立式 Vertical type (重量 Weight)	JT-4504 (約 about 115kg)	45	ER-11 JT-1 JT-2 Multi-Spindle Use	ø4 以下 Less than	ø2x8軸 ø2.6x4軸 ø3x2軸 spindles	33 ~ 310	225 x 230	3PH 4P 0.18KW (1/4HP)	1830	2200	100, 80, 72	0.15, 0.175, 0.2, 0.225,	81x60x96	150
									1300	1570	64, 56, 48, 44, 40	0.25, 0.3, 0.35, 0.4, 0.45, 0.5, 0.6, 0.7, 0.75		
直立式 Vertical type (重量 Weight)	JT-4508 (約 about 110kg)	45	JT-2 / CT12 Tap Collet	ø2 ~ ø8 以下 Less than (ø10)	ø3x10軸 spindles ø4 x 5軸 spindles ø5 x 2軸 spindles	33 ~ 310	225 x 230	3PH 4P 0.37KW (1/2HP)	1340	1600	80, 72, 64, 60, 56, 48, 44, 40, 36, 32, 28, 27, 26, 24, 20, 19, 18, (16)	0.4, 0.45, 0.5, 0.6, 0.7, 0.75, 0.8, 0.9, 1.0, 1.2, 1.25, (1.5) (1.75)	75x54x96	140
橫型 Horizontal type (重量 Weight)	JT-4508A (約 about 53kg)								420	500	61x52x71	75		

