

# JT-6516

攻牙機  
TAPPING MACHINE

攻牙行程  
TAPPING STROKE

最大攻牙  
MAX. TAPPING

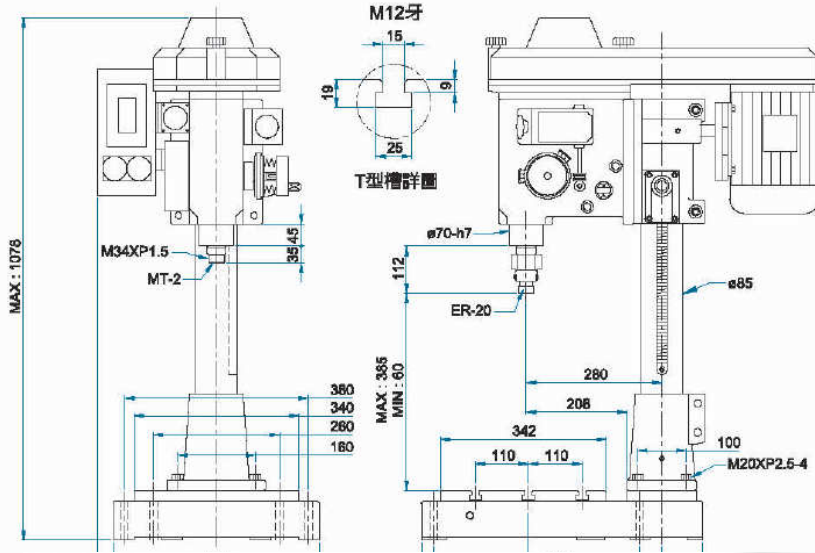

## 規格表 / Specification

機種 Model	規格 Specification	主軸最大行程 Main spindle max. stroke (mm)	主軸前部型式 Type of the front side of Main spindle (mm)	螺牙直徑 Diameter of thread (mm)	多軸最大能力 Max. capacity of Multi-spindle	主軸端和台之距離 Distance between the main spindle and the table (mm)	工作台尺寸 Working table size (mm)	馬達 Motor	主軸迴轉數 Main spindle speed (R.P.M)		符合本機器使用之自動送給螺距 Auto feeding thread pitch for which suits machine		裝箱尺寸 Packing dimension (cm)	毛重 G. Weight (kg)
									50HZ	60HZ	每英寸的牙數 Range of TPI	mm		
直立式 Vertical type (重量 Weight)	JT-6516 (約about: 220kg)	65	MT-2# / ER-20 Collet	ø5 ? ø16	ø6 x 9軸 spindles ø8 x 4軸 spindles ø12x2軸 spindles	60 ? 385	340 x 340	3PH 6P 0.75KW (1HP)	590	720	40,32, 28, 27,26, 24, 20,19, 18, 16,14, 13, 12,11, 10	(0.4, 0.45, 0.5, 0.6) 0.7, 0.75, 0.8, 0.9, 1.0, 1.25, 1.5, 1.75, 1.8, 2.0, 2.4, 2.5	99x62x117	270
橫型 Horizontal type (重量 Weight)	JT-6516A (約about: 106kg)													
直立式 Vertical type (重量 Weight)	JT-6532 (約about: 293kg)	65	MT-3# / Fixed Type Chuck	ø10 ? ø32	ø10x10軸 spindles ø16 x 4軸 spindles ø20x2軸 spindles	190 ? 630	340 x 380	3PH 6P 1.5KW (2HP)	280	340	19, 18, 16, 14, 13, 12, 11, 10, 9, 8, 7	1.25, 1.5, 1.75, 1.8, 2.0, 2.4, 2.5, 3.0, 3.5	102x69x138	350
橫型 Horizontal type (重量 Weight)	JT-6532A (約about: 140kg)													